

# **ESM-20 “RadMan” ESM-30 “RadMan XT” Radiation Monitor**

Operating Manual

DE Patent 19726138  
US Patent 5955954

BN 2250/98.21



# Contents

<b>Introduction</b>	Application and use . . . . .	3
	Functions and features . . . . .	4
<b>Safety</b>	Correct usage . . . . .	6
	Warning instructions . . . . .	7
<b>After unpacking</b>	Packing, Pack contents, Transport . . . . .	11
	Storage, Power supply . . . . .	12
<b>Operation and use</b>	Controls and displays . . . . .	13
	Switching on ESM “RadMan” . . . . .	14
	Normal operation . . . . .	16
	ESM-30 only: Data recorder . . . . .	18
	Operational readiness, Max Hold . . . . .	19
Applications and use . . . . .	21	
<b>Maintenance</b>	Checking field probe function . . . . .	33
	Repairs, Cleaning, Calibration . . . . .	35
	Changing the batteries . . . . .	36
<b>Specifications</b>	Specifications . . . . .	38
	General information . . . . .	44
	Environmental data . . . . .	45
<b>Ordering Information</b>	Instrument versions . . . . .	46
	Accessories . . . . .	48

**ESM-20 “RadMan”  
ESM-30 “RadMan XT”  
Radiation Monitor**

BN 2250/xx

BN 2251/xx

Operating Manual



If you have any questions, please contact your local sales office. The addresses are given at the end of this handbook.

## Copyrights

This product or parts of it are based upon Recommendations and/or Standards of the Standardization Sector of the International Telecommunication Union - ITU-T and/or of the European Telecommunications Standards Institute - ETSI. These Recommendations and Standards are subject to copyrights of these organizations. Without written permission of the ITU-T and/or ETSI it is not permitted to copy ITU-T Recommendations or ETSI standards or parts thereof and/or make them available to third parties.

Narda Safety Test Solutions GmbH  
Sandwiesenstr. 7, 72793 Pfullingen  
© 2001

Author: Joachim von Freeden  
Translators: John Nutley/Gary Hess

Order no.: 2250/98.21

Edition: 07/01.01

Previous Edition:  
06/00.10

Subject to change without notice  
Our normal guarantee and delivery terms apply

Printed in Germany

### About this manual

The ESM-30 “RadMan XT” differs from the ESM-20 “RadMan” in that it is equipped with a data recorder. Where both instruments are meant, the term ESM “RadMan” is used. Information that only applies to the ESM-30 “RadMan XT” is prefaced by “ESM-30 only”.

### Application

Early warning is required wherever humans are likely to be directly threatened by the presence of strong electromagnetic fields.

Antenna and radar equipment and machines which use strong electromagnetic fields to heat, weld or bond materials are typical sources of dangerous electromagnetic fields.

The ESM “RadMan” is a small, handy test and warning instrument which provides safe and timely warning of electromagnetic fields in these areas of application.

ESM “RadMan” measures according to the usual standards covering exposure to electromagnetic radiation.

### Use

The handy shape of the ESM “RadMan” makes it ideal for three main areas of use:

- As a warning unit - ESM “RadMan” is worn on the body by attaching it to clothing using the clip or to a belt using the belt pouch supplied.

## Functions and features

- As a monitor unit - ESM "RadMan" is used to check beforehand that limit values are not exceeded in areas where humans are present.  
To reduce the effects due to the body as far as possible, ESM "RadMan" is held at arm's length or the extension rod is used (option).
- As a locating unit - ESM "RadMan" can be used to locate leaks on waveguides and coaxial screw connectors.
- ESM-30 only:  
As a data recorder - ESM-30 "RadMan XT" automatically records all measurement values continuously. The data can be displayed and evaluated on a PC using the ESM-TS Interface Set, which is available as an option. All evaluations can be summarized in a report.

## Functions and features

In contrast with other instruments, the six sensors of the ESM "RadMan" independently monitor all the components of the electric and magnetic fields of a signal. This means the device can always measure the strongest field component. ESM "RadMan" measures isotropically, i.e. non-directionally.

International and national bodies have set different limit values for permissible electromagnetic radiation levels in various standards and regulations. Different versions of ESM "RadMan" are available to cover these differences (see page 39).

## Functions and features

Power is supplied from two standard batteries, giving a typical operating time of 200 hours.

A wide range of accessories ensures that the unit can be optimized for each particular type of application.

## Correct usage

This instrument left the factory in perfect condition. To ensure safe usage and to preserve it in good condition, please follow the safety instructions below.

The instrument must only be used under the conditions and for the purposes for which it was designed. For more information, see page 13 onwards and page 38 onwards.



### Warning

- Operation outside these conditions may be dangerous or may result in damage to the instrument.
- ⇒ Make sure that the instrument is operated within the limits for ambient conditions.
- ⇒ Make sure that the specified measurement range is not exceeded.
- ⇒ Always make sure that the instrument is in good condition before switching it on.





### Warning

#### General instructions governing the use of field strength measuring equipment

- Do not touch or use the field strength meter to touch items carrying dangerous voltages.
- Make sure that you know which laws, standards and regulations apply in your area. Read the operating manual carefully and seek expert advice if anything requires clarification.  
A selection of current standards and regulations is listed in this manual (see page 32).
- Be advised that working in the vicinity of strong radiation sources can endanger life.
- Be advised that persons fitted with electronic implants such as heart pacemakers may be especially at risk.
- Observe the local safety precautions specified by the operator of the plant or equipment.
- Make sure you follow the operating instructions when using equipment which generates, transmits or uses electromagnetic energy.



### Warning

- Never place or hold field strength measuring equipment inside field generating equipment or machines (e.g. microwave ovens or induction furnaces) as this may result in destruction of the field strength measuring equipment which is not designed to withstand field strengths intended for materials processing.
- Be advised that field strength increases rapidly in the near-field region (the field strength will be eight times higher if you halve the distance to the source). Enormous field strengths can occur in the immediate vicinity of radiation sources (e.g. leaks in waveguides, induction furnaces).
- All field strength measuring equipment has a limited and specified frequency range. Fields with spectral components outside this frequency range will normally not be evaluated correctly and may be underestimated. Before using field strength measuring equipment, make sure that all the field components to be measured are within the specified frequency range of the measuring equipment.



### Warning

- Be advised that secondary radiators (reflecting objects, such as a metal fence) may result in local amplification of field strength.
- The safety of persons within electromagnetic fields must not be based purely on the measured values produced by field strength measuring equipment, since the built-in redundancy is not sufficient to ensure that the instruments will always function correctly at all times.
- Be advised that the electromagnetic field strength may be underestimated by the field strength measuring equipment if your body is interposed between the radiation source and the field strength measuring equipment.
- Be advised that field strength measuring equipment cannot cover all aspects of a standard or regulation. Please therefore check the specifications to ascertain the extent to which the field strength measuring equipment meets the requirements of the applicable standard.
- Be advised that an underestimation of the electromagnetic field strength cannot be excluded if the field strength measuring equipment is worn on the body.  
The ESM “RadMan” has been specially

## Warning instructions

- constructed to exclude the possibility of underestimating the electromagnetic field strength as far as possible (see page 32).
- Be advised that field strength can be attenuated by wet clothing. ESM "RadMan" should be worn outside the clothing to exclude the possibility of underestimating the electromagnetic field strength.
  - Be advised that the strengths of pulsed signals (e.g. radar signals) may be wrongly estimated by field strength measuring equipment. The ESM "RadMan" is however designed so that with the type of radar signals normally encountered it deviates slightly from the actual rms value. The 2250/01, 2250/04 and 2250/06 models are particularly recommended for the VDE 0848, ENV 50166-2 and ICNIRP standards, which stipulate a special evaluation method for such signals. Contact your Sales Agent for more information, quoting the reference "Radar Application Note".
  - Strong, low-frequency electrical fields, for instance in the vicinity of high-voltage cables, may sometimes influence the displayed value, especially when the RadMan is used as a rapid tester or as a leak locator.

### Packing

Please retain the packing materials. These packing materials are designed so they can be reused. The original packing materials will reliably protect the device from damage in case you have to transport it later.

### Pack contents check

The following are included with your ESM “RadMan”:

- ESM “RadMan” with absorber cap
- Batteries, 2 pieces
- Holster
- Earphone
- Cover for optical interface
- Operating manual
- Calibration certificate

### Transport damage check

After unpacking the instrument check carefully for signs of damage that may have occurred during transport. This is particularly likely to be the case if the packing has been clearly damaged. Do not attempt to use an instrument that has been visibly damaged, as further damage may result.

### Recovery after storage and transport

The guaranteed operating temperature range of the instrument is -10 to +50 °C.

Condensation may form on equipment that has been stored or transported at low temperatures when it is brought into a warmer environment. To avoid damaging the instrument, wait until the condensation on the instrument has evaporated before switching on. If stored at a higher temperature, wait until it has cooled to within the operating range before switching on.

### Power supply

ESM “RadMan” is battery powered.

- Two 1.5 V batteries (alkaline manganese AAA size) operating life typically 200 hours.

ESM “RadMan” is shipped without batteries fitted.

### Fitting the batteries

- ⇒ Make sure that the ESM “RadMan” is switched off.
- ⇒ Fit the batteries (see page 36).
- ⇒ Switch the ESM “RadMan” on after changing the batteries and monitor the self test (see page 15).
- ⇒ ESM-30 only:  
Set the date and time to provide a reference for recorded data. To do this, use the ESM-TS Interface Set which is available as an option.

## Controls and displays

Item number <sup>1</sup>	Meaning
A	Threaded bush for tripod or extension rod
B	Eyelet for fixing the absorber cap to the ESM using nylon cord
C	Yellow absorber cap with fixing clip
D	Isotropic E-field probe
E	Isotropic H-field probe
F	Loudspeaker with earphone connector
G	LEDs for displaying alarm stages and operation ("heartbeat")
H	Indication of applicable standard and frequency range
I	Eyelet for fixing the absorber cap to the ESM using nylon cord
J	Optical interface (including cover) for reading out measurement values ESM-30 only: Also for data recorder configuration and readout
K	On / off switch
L	Battery compartment
<b>1</b>	<b>See the illustration on the last cover page of this manual.</b>

## Switching on ESM “RadMan”

### Automatic switch on routine

The switch on routine has four main steps.

The end of each step and the beginning of the next is signaled by a “beep”.

- **Step 1:**  
LED check
- **Step 2:**  
Battery charge state check
- **Step 3:**  
Function check of H-field sensor
- **Step 4:**  
Function check of E-field sensor

**Tip:** The field sensors are activated separately in step 3 and 4, so they can be independently tested.

A test generator can be used to perform an extended function check of the H- and E-field sensors. (see page 33).

### Switching on

⇒ Set the yellow on / off switch to the “ON” position.



## Switching on ESM “RadMan”

### After switching on

After you switch on the ESM “RadMan”:

1. The LEDs light up briefly one after another, starting with the 12.5% LED. A “beep” is then heard.
2. The battery charge state is indicated. One of the four LEDs lights up.
  - **100% LED means:** More than 75% of the battery capacity is available.
  - **50% LED means:** More than 50% of the battery capacity is available.
  - **25% LED means:** More than 25% of the battery capacity is available.
  - **12.5% LED means:** Less than 25% of the battery capacity is available.
  - No LED lit means: Batteries need changing (see page 36).A “beep” is then heard.
3. The H-field sensor is activated; the E-field sensor is inactive (see page 16). A “beep” is then heard.
4. The E-field sensor is activated; the H-field sensor is inactive (see page 16). A double “beep” is then heard.
5. ESM-30 only:
  - The data recorder is configured.
  - A triple “beep” is then heard.
  - The switch-on phase is complete.
  - The instrument is now ready for use.

## Normal operation

### Normal operation

The E- and H-fields are measured simultaneously during operation.

The larger of the two values is displayed.

If electromagnetic radiation is present, the ESM "RadMan" indicates the magnitude of the radiation level by means of four LEDs; alarms are additionally signaled by a beep from the loudspeaker.

**Tip:** If you want to measure the E and H fields separately when using your ESM, switch the unit off and then on again. The effective H field is displayed briefly during step 3 of the switch on routine. The effective E field is displayed briefly during step 4 (see page 15).

### Display of measured values

**12.5% LED** indicates: 12.5% of the power density (= 35% of the field strength) permitted by the relevant standard has been reached. This state is indicated by a yellow LED.

**25% LED** indicates: 25% of the power density (= 50% of the field strength) permitted by the relevant standard has been reached. This state is indicated by a yellow LED.

**50% LED** indicates **alarm state**: 50% of the power density (= 70.7% of the field strength) permitted by the relevant standard has been reached.

## Normal operation

This alarm state is indicated by a flashing red LED. The instrument will also emit an audible BEEP twice a second as an additional warning signal.

This status is maintained for as long as the ESM “RadMan” continues to measure this level of electromagnetic field strength.

**100% LED** indicates **alarm state**: 100 % of the power density (= 100% of the field strength) permitted by the relevant standard has been reached.

This alarm state is indicated by a flashing red LED. The instrument will also emit an audible BEEP 4 times a second.

This status is maintained for as long as the ESM “RadMan” continues to measure this level of electromagnetic field strength.

**Tip:** The effect of electromagnetic radiation on the human body is primarily related to the power density and not the field strength. For this reason, the display is calibrated in units of power density.

**Tip:** By noting the different BEEP repetition rates, you can easily locate the field maxima without looking at the LEDs.

## ESM-30 only: Data recorder

### Automatic recording of measured values

The measured values are automatically displayed and recorded when the instrument is switched on. A new block of data is started each time the instrument is switched on.

### Evaluating measurement values

The data blocks can be evaluated singly or together on a PC with the aid of the ESM-TS Interface Set, available as an option. All evaluations can be summarized and saved in a report.

### Configuring the data recorder

The interval between saving consecutive measurement values can be set within a wide range using the ESM-TS Interface Set. The data set saved at the end of the save interval contains the RMS value, the maximum and the minimum value from all the H field and the E field values that were measured during the save interval (measurement interval 5 ms).

## Operational readiness, Max Hold

The ESM “RadMan” indicates **operational readiness** every 10 seconds.

Operational readiness is indicated by an LED which depends on the electromagnetic radiation that has occurred or been measured. This also allows the magnitude of the highest measured value of electromagnetic radiation to be read off (**Max Hold**).

- Brief flashing of the 12.5% LED means: The highest measured value of electromagnetic radiation was below 25% of the power density permitted by the relevant standard.
- Brief flashing of the 25% LED means: The highest measured value of electromagnetic radiation was at least 25% of the power density permitted by the relevant standard but was less than 50% of the power density permitted by the relevant standard.
- Brief flashing of the 50% LED means: The highest measured value of electromagnetic radiation was at least 50% of the power density permitted by the relevant standard but was less than 100% of the power density permitted by the relevant standard.
- Brief flashing of the 100% LED means: The highest measured value of electromagnetic radiation was at least 100% of the power density (= 100% of the field strength).

**Tip:** Note the information regarding display of measured values (see page 16).

## Operational readiness, Max Hold

If the battery capacity is only sufficient for a few more hours of operation, the LED display of operational readiness is replaced by a brief “beep”.

Maximum value (Max Hold)	LED display	Battery status	Loud-speaker
$\geq 100\%$	100%	Full	-
$\geq 100\%$	100%	Empty	BEEP
$\geq 50\%$	50%	Full	-
$\geq 50\%$	50%	Empty	BEEP
$\geq 25\%$	25%	Full	-
$\geq 25\%$	25%	Empty	BEEP
$< 25\%$	12.5%	Full	-
$< 25\%$	12.5%	Empty	BEEP

### Resetting the Max Hold function

⇒ Switch the ESM “RadMan” off and then on again.

### Areas of use

ESM “RadMan” has the following main areas of use.

- As a warning unit
- As a rapid tester
- As a leak locator
- ESM-30 only:  
Data recorder

### General handling instructions

**Moving the instrument rapidly** in an electrostatic field can have a disruptive influence. The effects of this have been minimized in the ESM “RadMan” by means of special construction features. Despite this, moving the instrument very quickly can produce field strengths that are too high by several V/m.

**Tip:** Hold the ESM “RadMan” as still as possible to make accurate measurements.

**In the immediate vicinity** of a weak transmitter such as a cell phone, the alarm threshold can be exceeded locally without any actual risk arising. The standards implemented in the ESM “RadMan” are based on full-body exposure in a far-field. (Special standards apply to near-field measurements, e.g. on cell phones.)

**Tip:** Check whether the alarm persists at a minimum distance of 30 cm from the field source or from secondary radiators.

## Applications and use

### Using ESM as a personal warning unit

#### Application

The ESM “RadMan” is worn on the body, preferably by placing it in the breast pocket of your shirt or jacket.

#### Preparation

⇒ Slide the yellow absorber cap over the end of the instrument.

The labels “E-Field” and “H-Field” are no longer visible.

The clip should point to the LED side.

⇒ Slip the ESM “RadMan” into the breast pocket of your shirt or jacket, with the LED indicator side of the ESM “RadMan” pointing away from your body.

**Tip:** The ESM “RadMan” should lie flat against your body. Be advised that damp clothing can affect the measurement.





### Procedure

⇒ Stand in your normal working position and slowly turn around through a complete circle.

This allows ESM “RadMan” to better detect radiation sources that are behind your back when you are working normally.

⇒ If the alarm sounds, leave the danger area carefully and without panic.

**Tip:** If you are working in the vicinity of short-wave or very short wave transmitters, ESM “RadMan” may overestimate the levels of electromagnetic radiation that are present.

This is caused by proximity effects of the human body acting on the electromagnetic radiation. In such cases, hold the ESM “RadMan” in your hand or screw it on to the extension rod (accessory). Refer to the next section for details.

## Applications and use

### Using ESM as a rapid tester

#### Application

Wherever it is likely that electromagnetic radiation levels may be overestimated due to proximity effects of the human body (e.g. when working in the vicinity of short-wave or very short wave transmitters), use ESM “RadMan” as a rapid tester.

In this way, you can monitor your environment or get a quick picture of the field strengths that are present.

#### Preparation

- ⇒ Slide the yellow absorber cap over the battery compartment.  
The “narda” marking is no longer visible.  
Field reflections caused by the human body are no longer screened.  
The clip should point to the LED side.
- ⇒ If required: Screw the extension rod on to the absorber cap.
- ⇒ If required: Screw the yellow absorber cap to a non-metallic tripod.

#### Procedure

- ⇒ Check your environment for sources of electromagnetic radiation.
- ⇒ If required: Screw the extension rod on to the absorber cap.

⇒ After the check, screw the ESM “RadMan” to a non-metallic tripod so that you can work in the area and still be warned of any dangerous electromagnetic radiation levels.

**Tip:** The further the ESM “RadMan” is held away from your body, the more accurate the measurement as the proximity effects of the body are reduced.

**Tip:** If the ESM-TS Interface Set is used, the E-field and H-field strengths can be shown separately as percentages of the standard limit values (see page 30).

**Note:** The rapid tester function of the ESM “RadMan” is limited at frequencies < 27 MHz, e.g. medium-wave transmitters.

## Applications and use

### Using ESM as a leak locator unit

#### Application

The ESM “RadMan” is used to detect leaks in waveguides.

#### Preparation

- ⇒ Slide the yellow absorber cap over the battery compartment.  
The “narda” marking is no longer visible.  
The clip should point to the LED side.
- ⇒ If required: Screw the extension rod on to the absorber cap.

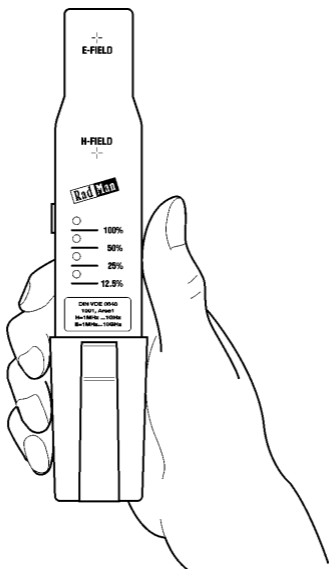

### Procedure

- ⇒ Hold the ESM “RadMan” at arm’s length.
- ⇒ Move the ESM “RadMan” slowly along the waveguide at a relatively large distance from it.
- ⇒ If a leak is suspected, slowly move the ESM “RadMan” closer to the suspected location.
- ⇒ Once the 100% alarm stage has been reached, do not move the instrument any closer to the waveguide.

**Tip:** The distance to the location of the leak should be a minimum of 3 cm, otherwise the effects of the ESM “RadMan” field sensors on the field to be measured can no longer be ignored.

**Tip:** To determine cable damage reliably, move ESM “RadMan” slowly over the cable being checked.

## Applications and Use

### Using ESM-30 as a data recorder

#### Applications

The data recorder records the variation with time of the surrounding electromagnetic radiation.

If ESM-30 “RadMan XT” is worn as a warning unit, the exposure of the wearer during the course of the working day can be recorded.

If ESM-30 “RadMan XT” is used as a rapid tester, it records the profile of the flux density in the area under test.

#### Procedure

- ⇒ Wear ESM-30 “RadMan XT” as a warning unit on the body as described above.
  - or –
- ⇒ Fit ESM-30 “RadMan XT” to a non-metallic tripod and use it as a rapid tester.
- ⇒ Switch the unit on to start testing.
- ⇒ Evaluate the recorded values using the ESM-TS Interface Set available as an option.

**Tip:** The ESM-TS Interface Set can be used to configure recording and to export the recorded data for evaluation using the software of your choice.

### Connecting the earphone

The earphone supplied can be connected to the ESM “RadMan” so that the audible alarm can still be heard reliably even in areas where high noise levels are present.

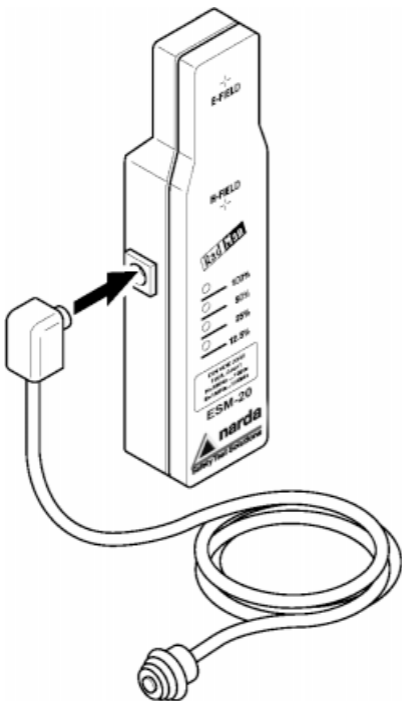

## Applications and Use

### Reading out measured values

The measured values can be read out via the optical interface (A) of the ESM "RadMan". Data is transferred at a rate of 25 measured values per second.

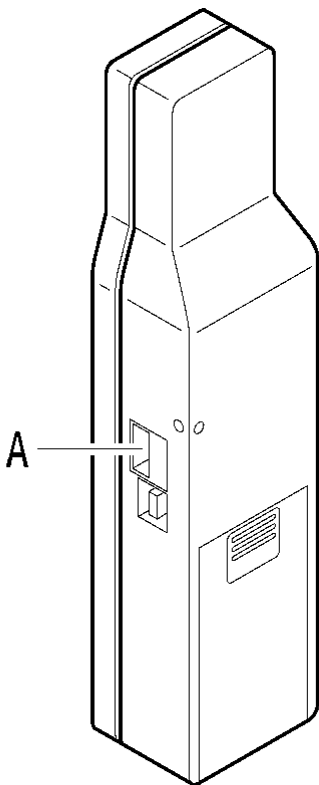



## Applications and Use

The E-field and H-field values are output separately with much higher accuracy than the LED display.

The ESM-TS Interface Set is required to read out the measured values from the ESM “RadMan”. This comprises software, a fiber optics cable and an opto-electric converter.

The software program allows a wide range of remote control functions and also allows measured values to be read out and saved.

ESM-30 only:

Data recorded using the ESM-30 “RadMan XT” can be easily evaluated in various ways and printed out as a report.

## Bibliography

### Standards and Guidelines

- DIN VDE 0848 Part 2 October 1991  
Safety in electromagnetic fields  
Protecting persons in the frequency range  
from 30 kHz to 300 GHz
- IEEE C95.1-1991, IEEE Standard for  
Safety Levels with Respect to Human  
Exposure to Radio Frequency  
Electromagnetic Fields, 3 kHz to 300 GHz
- WHO Environmental Health Criteria 137  
Electromagnetic Fields (300 Hz to  
300 GHz)
- ICNIPP, April 1998  
Guidelines for limiting exposure to time-  
varying electric, magnetic and  
electromagnetic fields (up to 300 GHz)

### Technical article

*Martin Schallner; Jan Waldmann; Stefan  
Hübner; Friedrich Landstorfer; Helmut Keller;  
and Rainer Bitzer:*

The Influence of the Human Body on Electric  
and Magnetic Field Components in the  
Immediate Vicinity of the Body.

Der Einfluß des menschlichen Körpers auf die  
elektrischen und magnetischen  
Feldkomponenten in unmittelbarer Nähe des  
Körpers.

“Frequenz”, Vol. 52 (September/October  
1998), pp. 170-174

Standards-compliant test of non-ionizing  
electromagnetic radiation on radar equipment.  
Author: Dr. Rainer Bitzer

See also [www.narda-sts.de](http://www.narda-sts.de)

## Checking field probe function

### Checking the function

The sensor functions of the ESM “RadMan” can be checked with the aid of a Test Generator (BN 2244/90.38).

The H-field and E-field sensors are tested separately.

1. Place the Test Generator in the vicinity of the sensors.
2. Press the blue button on the Test Generator.
3. Switch on the ESM.  
The self-test runs automatically.
4. Wait until the H-field sensor is checked  
At least the 12.5% LED must light up.
5. Wait until the E-field sensor is checked.  
At least the 12.5% LED must light up.
6. Switch off the Test Generator.

**Tip:** Switch the Test Generator off before you hear the double “beep”, otherwise the ESM “RadMan” will save the measured value of radiation (Max Hold).

If you switch off the Test Generator after the double “beep”, switch the ESM “RadMan” off and then on again to clear the Max Hold state.

## Checking field probe function

**Tip:** Make sure that the Test generator batteries are not run down, otherwise the output power of the generator will be insufficient to properly test the field sensors.

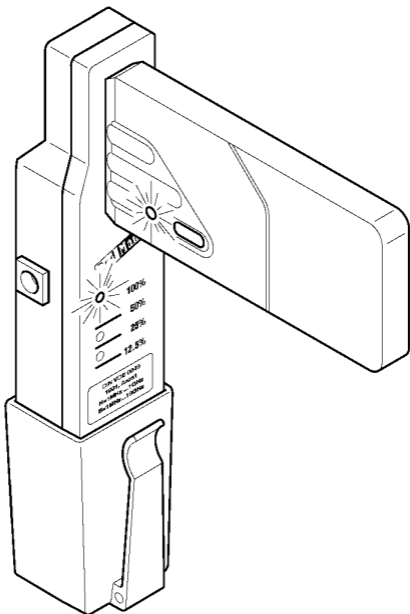

Although performing an extended self-test with the aid of the Test Generator may permit a fault to be detected, it provides no guarantee that all sensors are measuring correctly, for instance after inexpert handling such as when they are dropped from a great height. If in

## Repairs, Cleaning, Calibration

doubt, we therefore advise you to return the equipment to the manufacturer for more comprehensive testing.

### Repairs

ESM “RadMan” may only be repaired by authorized service centers. Please contact your sales office.

The casing screws are sealed.

If the casing screw seals are damaged, no guarantee claims will be entertained.

### Cleaning

Use only warm water to which a little detergent has been added for cleaning the casing of the ESM “RadMan”.

Moisten a soft cloth with this and wipe off the surface of the ESM “RadMan” casing.

Make sure that water does not get in behind the LEDs, loudspeaker, optical interface, on / off switch.

### Calibration

Each ESM “RadMan” is calibrated and adjusted before it leaves the factory.

Each instrument is calibrated and adjusted separately for the E-field and H-field at the alarm threshold of 100 MHz (27.12 MHz for version /08, /58 or 200 MHz for version /05, /55) and at 50% of standard limit value.

The E- and H-field sensors are calibrated and adjusted separately.

## Changing the batteries

It is recommended that the instrument be recalibrated every three years.

If your ESM “RadMan” requires calibration and adjustment, contact your nearest Service Center.

### Changing the batteries

**Tip:** Only use 1.5 V AAA size alkaline manganese batteries.

1. ESM-30 only:  
Switch on the ESM-30 “RadMan XT” and monitor the self test (see page 15).  
If none of the LEDs lights up during the test, you should set the date and time again after you have replaced the batteries.
2. Switch off the ESM “RadMan”.
3. Replace the old batteries with fresh ones.  
Make sure that they are inserted with correct polarity (see page 37).
4. Switch the ESM “RadMan” on after replacing the batteries and monitor the self test routine.
5. ESM-30 only:  
If none of the LEDs lit up during the test (item 1 above) it is a good idea to set the date and time again now using the ESM-TS Interface Set, which is available as an option.

## Changing the batteries

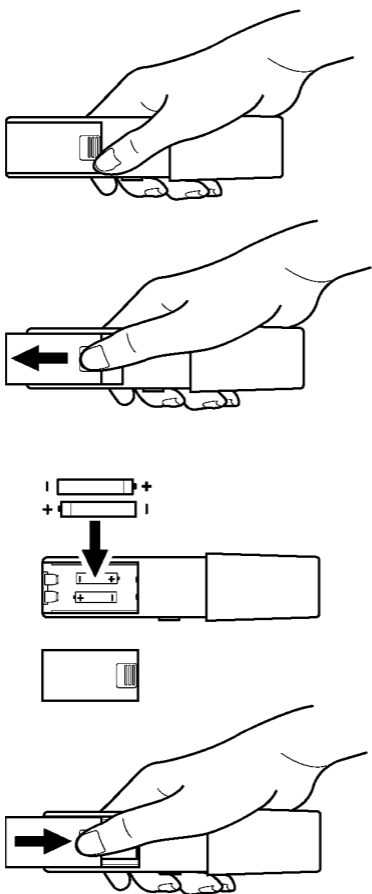

## Specifications

### Miscellaneous

All the data specified here is valid under the following conditions unless otherwise stated:

- ✓ Sinusoidal signals
- ✓ The instrument is located in the far field region of the source
- ✓ Ambient temperature:  $23\text{ °C} \pm 3\text{ °C}$
- ✓ Relative humidity: 25% to 75%

The data include all relevant partial errors for calculating the overall error to IEC 359.

### Alarm threshold at the calibration frequency

- 50% of standard value  $\pm 1.0\text{ dB}$ , individually calibrated.

Calibration frequency	Version
200 MHz	.../05 and .../55
27.12 MHz	.../08 and .../58
100 MHz	All others

### Visible display

- Display using 4 LEDs  
Thresholds at 12.5%, 25%, 50% and 100% of standard value
- Scale division error  $\pm 5\%$  of standard value
- The display is calibrated in terms of relative power flux density. 50% of the power flux density of the standard corresponds to an E-field or H-field strength of 70.7% of the limit value in the relevant standard.



- The E- and H-field components are measured simultaneously. The largest value is displayed.

### Audible warning

- Built-in loudspeaker
- Audible alarm if alarm threshold exceeded (50% of relevant standard value)
- BEEP repetition rate: 2 Hz starting at 50% of standard, 4 Hz starting at 100% of standard.

### Frequency response evaluation and limit values according to different standards

ESM “RadMan” is available in a wide range of different versions. Please refer to the tables on page 46 and page 47. The frequency range values printed on the instrument apply in each case.

### Frequency response

Frequency response referred to calibration frequency with ideal approximated limit curve

Sensor	Frequency range	Typical deviation
H-field	up to 1 GHz	+3 dB / -3 dB
E-field	up to 3 GHz	+3 dB / -3 dB
	3 GHz to 10 GHz	+4 dB / -3 dB
	10 GHz to 18 GHz	+6 dB / -3 dB
	18 GHz to 40 GHz	+6 dB / -10 dB

The limit value traces in the standards exhibit sharp edges. These limit value traces are simulated in the ESM “RadMan” by means of

## Specifications

equalizer networks. The frequency response quoted refers to the characteristic of an ideal equalizer circuit containing only 1st order decoupled components.

The H-field sensor should not contribute to the measured signal at frequencies above 1 GHz, and may at most only contribute the amount that would accrue if it were specified up to 18 GHz. The H-field sensor may cause a slight overestimation of the actual exposure level in narrow frequency ranges above 1 GHz.

### Isotropy

Isotropy  
(27 MHz to 500 MHz). . . . . +4/-2 dB typ.

### RMS error

RMS error . . . . .  $\pm 0.2$  dB typ.  
(for 8 CW signals of same exposure in the entire display range)

### Overload protection

CW over standard . . . . . +20 dB, but not more  
than 10 kV/m  
or 26.5 A/m

Pulse < 10  $\mu$ s. . . . . +40 dB, but not more  
over standard than 100 kV/m  
or 256 A/m

Temperature response  
(-10 °C to 55 °C) . . . . . +0.5/-1.5 dB

## Specifications

### **ESM-30 only: Data recorder**

#### *Save interval:*

The time between consecutive saves of recorded data can be set between 1 second and 3 minutes using the ESM-TS Interface Set.

#### *Data set:*

The r.m.s., maximum and minimum values are calculated continuously during the selected save interval (the interval between measurements is 5 ms, all data are referred to the relevant permitted power flux density in the same way as the displayed value).

The data for the E-field and H-field are saved in the data recorder as a data set with a timestamp at the end of the each save interval.

#### *Data block:*

All data sets recorded between switching on and switching off the ESM-30 “RadMan XT” are combined into a data block. Several data blocks can be stored in the data recorder at any one time. These data blocks are accessed by the ESM-TS Interface Set for evaluation.

#### *Capacity:*

The typical capacity is 1600 data sets, corresponding to about 27 hours operation at a save interval of 1 minute. The oldest recorded values will be overwritten if the memory capacity is exceeded (ring memory).

#### *Built-in clock:*

Date and time data are provided from a built-in clock module, which is powered from the

normal batteries. You have at least 30 seconds in which to change the batteries if the ESM-30 “RadMan XT” is switched on before replacing the batteries and the self test has been completed successfully. Otherwise, you should check the time settings. The date and time are set using the ESM-TS Interface Set which is available as an option.

### Interfaces

The data from the E-field and H-field probes can be output separately using the optional ESM-TS Interface Set.

- The resolution of the data is 0.625% of the standard limit value in this case.
- 25 measured values are transferred per second.

ESM-30 only:

The following additional functions are available:

- Read out values recorded in the data recorder.  
The transfer time for all the data when the data recorder is completely full is less than 5 minutes.
- Select the save interval:  
The time between consecutive saves of recorded data can be set in several steps between 1 second and 3 minutes.
- Set date and time.
- Comprehensive evaluation, storage and exporting of data.

## General information

### Power supply

Batteries . . . . . 2 size AAA,  
alkaline manganese  
primary cells

Operating time. . . . . typ. 200 hours if  
LEDs and alarm off

Battery  
status display. . . . . by LEDs when  
switching on the unit

### Dimensions

26.0 mm x 36.4 mm x 157 mm

With cap

as absorber . . 36.6 mm x 41.0 mm x 163 mm

With cap

as grip . . . . . 36.6 mm x 41.0 mm x 197 mm

### Weight

Including cap and batteries . . . . . 130 g

### Calibration

Each instrument is calibrated and adjusted separately for the E-field and H-field at the alarm threshold of 100 MHz (27.12 MHz for version /08, /58 or 200 MHz for version /05, /55) and at 50% of standard limit value.

The recommended calibration interval is every 3 years.

### Ambient temperature

Nominal range of use. . . . . -10 °C to 55 °C

Storage and transport . . . . . -40 °C to 70 °C

### Environment classes

Unless otherwise stated, the specifications apply within the range of environment classes IEC 721-3-7 IE 73 with 7M3

### Interference generation and suppression

to . . . . . EN 50 081-1 and EN 50 082-1

## Instrument versions

### ESM-20 "RadMan"

Standard	Frequency range		Order number (BN) Short integration time <sup>1</sup>	Order number (BN) Long integration time <sup>2</sup>
	H-field	E-field		
DIN VDE 0848, Part 2, Oct. 1991, Area 1	1 MHz to 1 GHz	1 MHz to 40 GHz	2250/01	2250/51
FCC 96-326, Aug. 1996, occupational	3 MHz to 1 GHz	3 MHz to 40 GHz	2250/02	2250/52
Japan, RCR-STD-38, working	3 MHz to 1 GHz	3 MHz to 40 GHz	2250/03	2250/53
ENV 50166-2, Jan. 1995, occupational	27 MHz to 1 GHz	1 MHz to 40GHz	2250/04	-
IEEE C95.1-1991, controlled	3 MHz to 1 GHz	3 MHz to 40 GHz	2250/05	2250/55
ICNIRP, 1998, occupational	27 MHz to 1 GHz	1 MHz to 40 GHz	2250/06	2250/56
AS/NZS 2772.1, 1998, occupational	1 MHz to 1 GHz	1 MHz to 40 GHz	2250/07	-
NRPB, 1993, adult	27 MHz to 1 GHz	1 MHz to 40 GHz	2250/08	-
ÖNORM S 1120, 1992, occupational	3 MHz to 1 GHz	3 MHz to 40 GHz	2250/09	-
Canada, Safety Code 6, 1993, occupational	1 MHz to 1 GHz	1 MHz to 40 GHz	2250/10	2250/60

1 Integration time of E-field sensor: 30 ms/ H-field sensor: 1 s

2 Integration time of E-field sensor: 1 s/ H-field sensor: 1 s

The frequency range values printed on the instrument are applicable in each case.



## Instrument versions

### ESM-30 "RadMan XT"

Standard	Frequency range		Order number (BN)
	H-field	E-field	
DIN VDE 0848, Part 2, Oct. 1991, Area 1	1 MHz to 1 GHz	1 MHz to 40 GHz	2251/01
FCC 96-326, Aug. 1996, occupational	3 MHz to 1 GHz	3 MHz to 40 GHz	2251/02
ICNIRP, 1998, occupational	27 MHz to 1 GHz	1 MHz to 40 GHz	2251/06
NRPB, 1993, adult	27 MHz to 1 GHz	1 MHz to 40 GHz	2251/08

### ESM-30 "RadMan XT ELF-immune"

Norm	Frequency range		Order number (BN)
	H-field	E-field	
DIN VDE 0848, Part 2, Oct. 1991, Area 1	1 MHz to 1 GHz	27 MHz to 40 GHz	2251/71
FCC 96-326, Aug. 1996, occupational	3 MHz to 1 GHz	27 MHz to 40 GHz	2251/72
ICNIRP, 1998, occupational	27 MHz to 1 GHz	27 MHz to 40 GHz	2251/76

The frequency range values printed on the instrument are applicable in each case.

All ESM-30 "RadMan XT" and "RadMan XT ELF-immune" have a long integration time.

## Accessories

### Standard accessories

Earphone for audible alarm . . .	BN 2250/92.01
Holster . . . . .	BN 2256/90.01
Operating manual, German . . . . .	BN 2250/98.01
English. . . . .	BN 2250/98.21
French . . . . .	BN 2250/98.41

### Optional accessories

27 MHz Test Generator . . . . .	BN 2244/90.38
Extension rod . . . . .	BN 2250/92.02
Floor tripod . . . . .	BN 2250/90.31
Table-top tripod . . . . .	BN 2250/90.32
ESM-TS Interface Set . . . . .	BN 2251/90.50



## Narda Safety Test Solutions

Sandwiesenstrasse 7  
72793 Pfullingen  
Germany  
Int'l phone +49-7121-9732-21  
Int'l fax: +49-7121-9732-90  
e-mail: [support@narda-sts.de](mailto:support@narda-sts.de)  
<http://www.narda-sts.de>

435 Moreland Road  
Hauppauge, NY 11788  
USA  
USA phone: 631-231-1700  
USA fax: 631-231-1711  
e-mail: [nardaeast@L-3com.com](mailto:nardaeast@L-3com.com)  
<http://www.nardamicrowave.com>

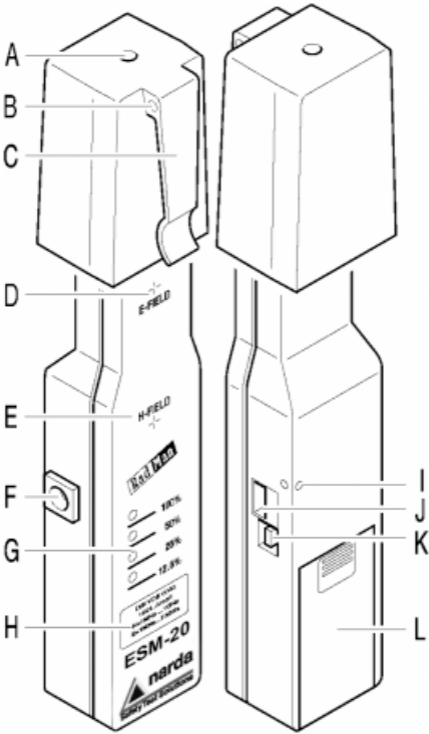

The key to this diagram is shown on page 13.



## ESM “RadMan”

BN 2250/xx and BN 2251/xx

### Brief operating instructions

#### After switching on

1. The LEDs light up briefly one after another, starting with the 12.5% LED.  
A “beep” is then heard.
  2. The battery charge state is indicated. One of the four LEDs lights up.
    - **100% LED means:** More than 75% of the battery capacity is available.
    - **50% LED means:** More than 50% of the battery capacity is available.
    - **25% LED means:** More than 25% of the battery capacity is available.
    - **12.5% LED means:** Less than 25% of the battery capacity is available.
    - No LED lit means: Batteries need changing. ESM “RadMan” will soon no longer be operational.A “beep” is then heard.
  3. The H-field sensor is activated; the E-field sensor is inactive.  
A “beep” is then heard.
  4. The E-field sensor is activated; the H-field sensor is inactive.  
A double “beep” is then heard.
  5. ESM-30 only:  
The data recorder is configured.  
A triple “beep” is then heard.
- The instrument is now ready for use.